

Technical Survey of Nitrogen Removal Alternatives for the Deer Island Treatment Plant

Massachusetts Water Resources Authority

Environmental Quality Department
ENQUAD Report ms-090



March 9, 2004

Ms. Linda Murphy, Director
Office of Ecosystem Protection
U.S. Environmental Protection Agency
Water Technical Unit "SEW"
P.O. BOX 8127
Boston, MA 02114

Mr. Glenn Haas, Director
Division of Watershed Management
Department of Environmental Protection
1 Winter Street
Boston, MA 02108

RE: Massachusetts Water Resources Authority Permit Number MA0103284
Part 8.e.i, Nitrogen Removal Technologies Technical Survey

Dear Ms. Murphy and Mr. Hass:

Enclosed find the 2003 update to the *Technical Survey of Nitrogen Removal Alternatives for the Deer Island Treatment Plant*. This report updates the survey of nitrogen removal technologies with nitrogen monitoring data from fiscal year 2003, and is required by the MWRA's NPDES permit.

If you require additional information or need clarification, please contact Grace Bigornia-Vitale at (617) 788-4716.

Sincerely,

Michael J. Hornbrook
Chief Operating Officer

cc: Eric Hall, USEPA, Region 1
Janet Labonte-Deshais, USEPA, Region 1
Catherine Coniaris, DEP, Boston

Bigornia-Vitale G and Wu D. 2004. Technical Survey of Nitrogen Removal Alternatives for the Deer Island Treatment Plant. Boston: Massachusetts Water Resources Authority. Report ms-090. 44 p.

***Technical Survey Of Nitrogen Removal Alternatives for
the
Deer Island Treatment Plant***

***Updated by:
Grace Bigornia-Vitale
David Wu***

Massachusetts Water Resources Authority
Environmental Quality Department
100 First Avenue
Boston, MA 02129

February 23, 2004
ms-090

Table of Contents

| | |
|--|-----------|
| Executive Summary | 1 |
| Section 1 – Introduction..... | 3 |
| 1.1 Purpose of Report | 3 |
| 1.2 Content of Report | 3 |
| Section 2 - Basic Planning Criteria | 4 |
| 2.1 Existing Facilities | 4 |
| 2.2 Available Space | 4 |
| 2.3 Flows and Loads..... | 8 |
| 2.3.1 Flows | 8 |
| 2.3.2 Nitrogen Loads | 11 |
| 2.4 Basic Design Information | 15 |
| 2.4.1 Wastewater Temperature | 15 |
| 2.4.2 Design Flows and Loads..... | 15 |
| 2.4.3 Design Effluent Quality | 17 |
| Section 3 – Screening of Alternatives..... | 18 |
| 3.1 Physical/Chemical Processes | 18 |
| 3.2 Biological Processes..... | 19 |
| 3.2.1 Suspended Growth Systems | 19 |
| 3.2.2 Fixed Growth Systems..... | 20 |
| 3.2.3 Hybrid Systems | 22 |
| 3.3 Systems Retained for Further Evaluation | 24 |
| Section 4 - Evaluation of Alternatives..... | 25 |
| 4.1 Biological Aerated Filters and Submerged Packed-Bed Reactors | 25 |
| 4.2 Biological Aerated Filters and Fluidized-Bed Reactors..... | 26 |
| 4.3 Moving-Bed Biofilm Reactors | 26 |
| 4.4 Common Elements | 35 |
| 4.4.1 Oxygen Requirement..... | 35 |
| 4.4.2 Chemical Requirements..... | 35 |
| 4.4.3 Sludge Processing..... | 35 |
| 4.5 Recommendations for Future Consideration | 36 |
| 4.5.1 Separate Treatment at Fore River..... | 36 |
| 4.5.2 Decreasing Requirement for Methanol | 36 |
| 4.5.3 Testing at Pilot Plant | 37 |

Tables

| | | |
|-----|--|----|
| 2-1 | Facilities at Deer Island Treatment Plant | 6 |
| 2-2 | Summary of Nitrogen Monitoring Results | 12 |
| 2-3 | Flows and Nitrogen Loads | 17 |
| 3-1 | Alternatives for Controlling Nitrogen at the Deer Island Treatment Plant | 23 |
| 3-2 | Systems for Further Evaluation | 24 |
| 4-1 | Biological Aerated Filter for Nitrification and Submerged Packed-Bed Reactors for Denitrification | 27 |
| 4-2 | Biological Aerated Filter for Nitrification and Fluidized-Bed Reactors for Denitrification | 29 |
| 4-3 | Moving-Bed Biofilm Reactor for Nitrification | 32 |
| 4-4 | Moving-Bed Biofilm Reactor for Denitrification | 33 |

Figures

| | | |
|------|---|----|
| 2-1 | Deer Island Site Plan | 5 |
| 2-2 | Space Available for Nutrient Control | 7 |
| 2-3 | Deer Island Process Flow Diagram | 9 |
| 2-4 | FY02-03 Daily Average Flow | 10 |
| 2-5 | FY02-03 Monthly Average Flow | 10 |
| 2-6 | FY02-03 Total Nitrogen Load to Primary Clarifiers | 14 |
| 2-7 | FY02-03 Total Nitrogen Load from Plant Effluent Streams | 14 |
| 2-8 | FY02-03 North System Influent Temperature | 16 |
| 2-9 | FY02-03 South System Influent Temperature | 16 |
| 2-10 | FY02-03 Final Effluent Temperature | 17 |
| 4-1 | Proposed Layout for BAF/SPBR Option | 28 |
| 4-2 | Proposed Layout for BAF/FBR Option | 30 |
| 4-3 | Proposed Layout for Nitrification/Denitrification MBBR Option | 34 |

Executive Summary

Section 8.e.i of MWRA's NPDES discharge permit (No. MA0103284) requires MWRA to "maintain a comprehensive technical survey of effective treatment technologies for nitrogen removal which are applicable to the Deer Island treatment facility." The purpose of the survey is to "facilitate the speedy selection and implementation of nitrogen removal technology if necessary."

The requirement for the survey grows out of concern about the possible impacts of nitrogen, a nutrient, on the Massachusetts Bay ecosystem. Worries that the additional nitrogen in effluent might lead to low dissolved oxygen or undesirable algal blooms in the Bay prompted the inclusion of the above clauses in the permit. Should MWRA need to cut down on nitrogen discharges, the survey will allow MWRA to quickly make an informed decision on available removal options.

This report updates reports submitted in November 2001¹ and June 2003.² The design criteria for the selection of alternative treatment remain unchanged and are based on their suitability at Deer Island, process reliability, and land and space requirements.

Approximately 13 acres of usable area exist for siting potential nitrogen removal facilities. This area would allow for the construction of nitrogen removal facilities without significantly encroaching on the landforms that were constructed to mitigate noise and visual impacts on the Town of Winthrop.

Results of nitrogen monitoring conducted for the period July 2001 to June 2003 support the assumptions and estimates used in the original evaluation of treatment options. All three alternatives presented in the earlier studies are still found to be viable options at the Deer Island site. These treatment alternatives are biological aerated filters with submerged packed-bed reactors, biological aerated filters with fluidized-bed reactors, and moving-bed biofilm reactors. The evaluation consisted of sizing and siting facilities based on available space and wastewater flows and loads at the Deer Island Treatment Plant.

Biological nitrogen removal technologies appear to be the most cost-effective method of nitrogen removal at this time. A research project entitled *Sustainable Technology for Achieving Very Low Nitrogen and Phosphorus Effluent Levels*³, funded by the Water Environment Research Foundation, is underway. This 2-year effort will assess a variety of technologies to determine the feasibility and cost benefits of nutrient

¹ Camp Dresser and McKee, *Technical Survey of Nitrogen Removal Technologies for the Deer Island Treatment Plant*, July 2001.

² Massachusetts Water Resources Authority, *Technical Survey of Nitrogen Removal Technologies for the Deer Island Treatment Plant*, June 2003.

³ Progress. *Water Environment Research Foundation*, Spring 2003 Newsletter, Vol 14(2).

Executive Summary

reduction to treatment plants around the nation. MWRA will continue to monitor the progress of this project as well as review emerging technologies for applicability to Deer Island.

Section 1

Introduction

1.1 Purpose of Report

MWRA's NPDES permit requires maintenance of a comprehensive technical survey of nitrogen removal technologies that are applicable to the Deer Island Treatment Plant. This report updates the previous report *Nitrogen Removal Alternatives for the Deer Island Wastewater Treatment Facilities* released in June 2003. This update will help to facilitate selection and implementation of nitrogen removal technology if such technology is required at Deer Island.

1.2 Content of Report

This report describes existing conditions at the Deer Island site, and identifies and evaluates various treatment alternatives capable of providing nitrogen removal at the Deer Island facility.

Section 2 begins with a description of existing facilities and of the remaining space available at Deer Island for siting nitrogen removal facilities. Section 2 also presents the most current nitrogen monitoring data available and updates estimates of flows and nitrogen loads used in the previously submitted reports.

Section 3 discusses processes available for nitrogen removal. This section summarizes physical/chemical nitrogen removal and biological nitrification and denitrification technologies. Processes are evaluated for applicability to the Deer Island site, and viable alternatives are selected for a more in-depth review.

Section 4 investigates the alternatives selected in Section 3 for further review. Each alternative is sized to determine feasibility of implementation. Elements common to all three options, such as oxygen and chemical needs and sludge production, are evaluated separately. Section 4 also lists other considerations that should be evaluated in the selection of treatment alternatives.

Section 2

Basic Planning Criteria

This section reviews existing facilities and identifies available space that could be used for Nitrogen removal facilities. In addition, this section summarizes FY03 (July 2002 – June 2003) nitrogen monitoring, updates flows and nitrogen loads, and presents basic information used for selecting facilities.

2.1 Existing Facilities

The Deer Island Treatment Plant (Deer Island) is a pure oxygen activated sludge process treatment plant with a design average flow of 540 mgd and hydraulic capacity of 1270 mgd. Figure 2-1 depicts the DITP site layout and Table 2-1 lists major facilities and pertinent information regarding those facilities.

2.2 Available Space

Nitrogen removal would require additional facilities for wastewater treatment and solids processing. The goal of this analysis is to site these facilities in areas previously allocated for treatment processes or support facilities that were not built, and to avoid construction on the landforms developed to lessen the impact of wastewater treatment facilities on Winthrop.

Areas available for nitrogen removal facilities are highlighted on Figure 2-2 and include:

- Area A: 5.7 acres, the space west of existing secondary Batteries
- Area B: 0.4 acres, the area to the north of the secondary clarifiers
- Area C: 3.2 acres, the area north of Batteries B, C, and D, and
- Area D: 3.5 acres, the area located north of the maintenance dry storage warehouse

While the total available gross area is 12.8 acres, piping and operational considerations limit the use of available space and each option with its particular design requirements needs more in-depth evaluation for its feasibility. Section 4 presents these conceptual design evaluations.

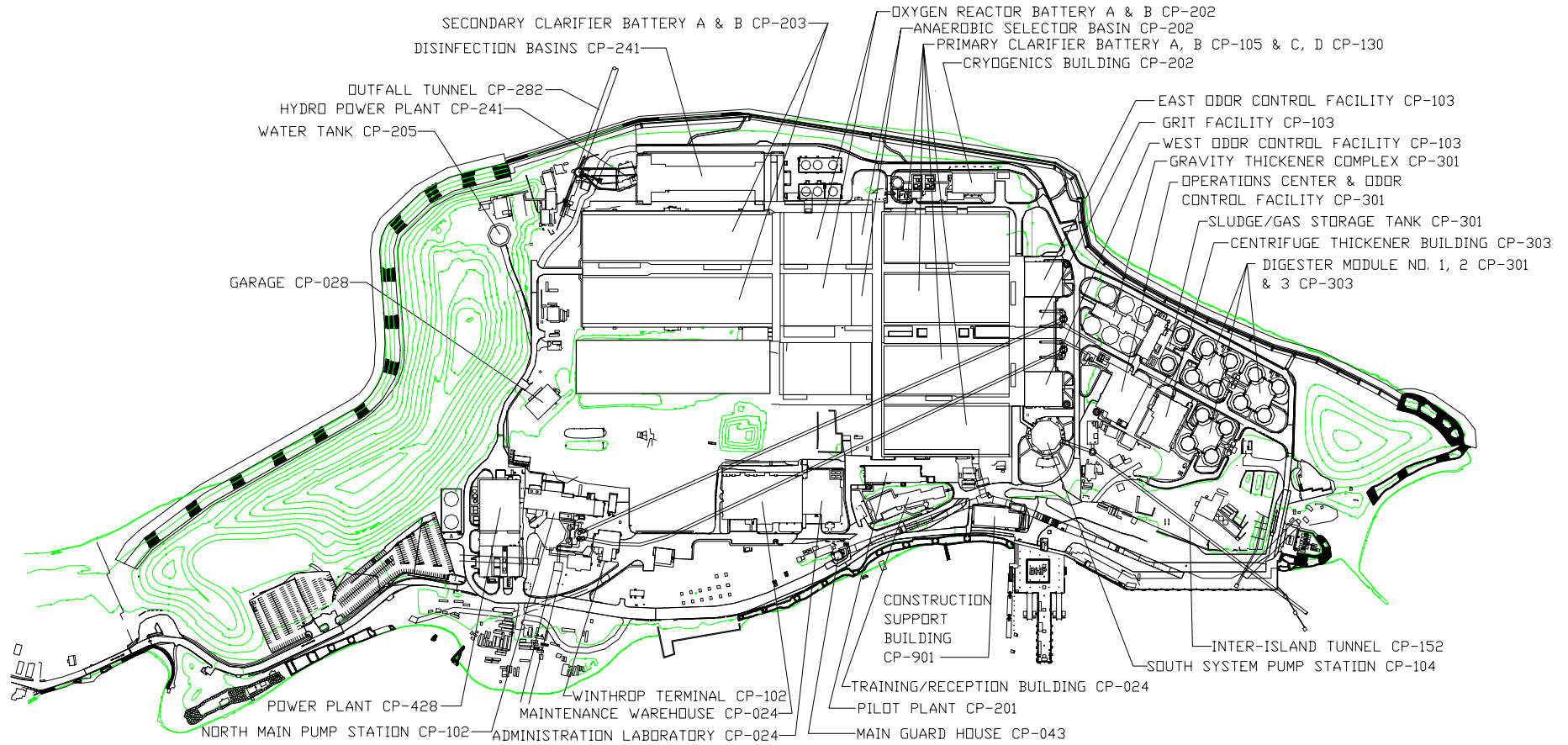
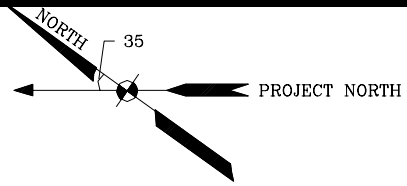

Figure 2-1
Deer Island Site Plan

**Table 2-1
Facilities at Deer Island Treatment Plant**

| | |
|--|------------|
| Stacked Rectangular Primary Clarifiers | |
| Number of batteries | 4 |
| Clarifiers per battery (stacked sets) | 12 |
| Effective surface area per clarifier (ft ²) | 15,252 |
| Aeration Tanks | |
| Number of batteries | 3 |
| Number of trains per battery | 3 |
| Total number of trains | 9 |
| Number of stages for selectors | 3/train |
| Volume of selectors per train (MG) | 1.07 |
| Number of aeration stages per train | 4 |
| Aeration volume per train (MG) | 3.55 |
| Stacked Rectangular Secondary Clarifiers | |
| Number of batteries | 3 |
| Clarifiers per battery (stacked sets) | 18 |
| Effective surface area per clarifier (ft ²) | 13,940 |
| Gravity Thickeners (for Primary Sludge) | |
| Number of units | 6 |
| Diameter (ft) | 70 |
| Sidewater depth (ft) | 12 |
| Centrifuges for Thickening Waste Activated Sludge | |
| Number | 12 |
| Allowable range flow/centrifuge (gpm) | 300 to 900 |
| Anaerobic Digesters/Thickened Sludge Storage | |
| Number of digesters | 12 |
| Volume of each digester (MG) | 3.0 |
| Number of storage tanks | 2 |
| Diameter (ft) | 90 |
| Total depth (ft) | 130 |
| Volume each (MG) | 3.0 |
| Centrifuges for Thickening Digested Sludge* | |
| Number | 4 |
| Allowable range flow/centrifuge (gpm) | 350 to 800 |

*Available for other use after pumping to Fore River is implemented

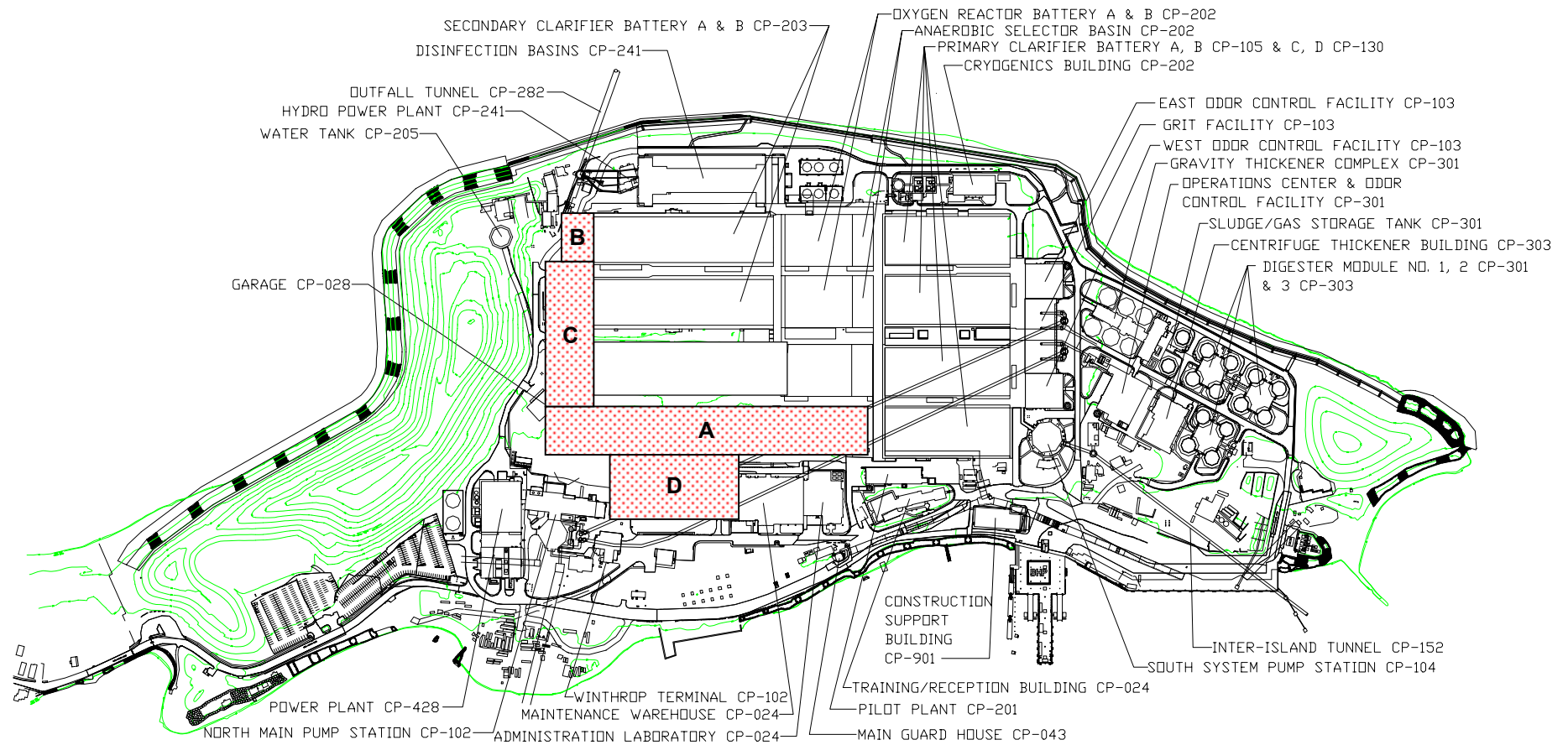
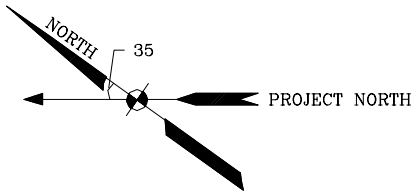

Figure 2-2
Space Available for Nutrient Control

2.3 Flows and Loads

This section provides a summary of monitoring results conducted during the period July 2001 to June 2003 and quantifies nitrogen loads from the various wastewater streams. These new load calculations update the estimates that were used in developing and sizing the conceptual designs of the selected nitrogen removal alternatives in the July 2001 report.

In addition to the required NPDES permit influent and effluent monitoring, MWRA implemented a comprehensive nitrogen monitoring program¹. The program aims to characterize wastewater streams within the treatment plant. Data produced will facilitate the selection, and if necessary, the design of nitrogen removal facilities at Deer Island.

Figure 2-3 shows the Deer Island process flow diagram and the various sampling locations along the process. South system flow arrives at the Deer Island's south system pump station via the inter-island tunnel and combines with the north system flow after the grit facility. This combined flow of raw wastewater is characterized by taking the flow-weighted average of the individual north and south system measurements. Continuous return streams from residual processing are piped back to the head of the primary clarifier. While these waste streams can be considered negligible when compared to the influent flow, their nitrogen concentrations are high and they could contribute significant nitrogen loads. The influent nitrogen load to the primary clarifier is therefore the flow-weighted average of these recycle streams and the flow-weighted average of the raw influent.

2.3.1 Flows

For the monitoring period, the average daily flow from the combined north and the south system was 347 mgd. The highest monthly average flow, which occurred in April 2003, was 527 mgd. These two averages will be evaluated and compared to conceptual design flows that were established in design configurations in the earlier report. Figure 2-4 shows the daily effluent flow while Figure 2-5 graphs the monthly averages.

The return flows from residual processing are continuous. These return streams include the overflow from the primary sludge gravity thickener, centrate from the secondary sludge centrifuge, and centrate from the digested sludge centrifuge. The flows from the gravity thickener, waste sludge centrate, and digested sludge centrate average 4.73 mgd, 5.1 mgd, and 0.87 mgd, respectively. When added to the raw wastewater influent, total flow to the primary clarifier averaged 358 mgd.

¹ Coughlin, Kelly. October 30, 2000. *Combined Work/Quality Assurance Project Plan for Nitrogen Monitoring in Deer Island Treatment Plant Waste Streams*. ENQUAD Technical Report 2000-16.

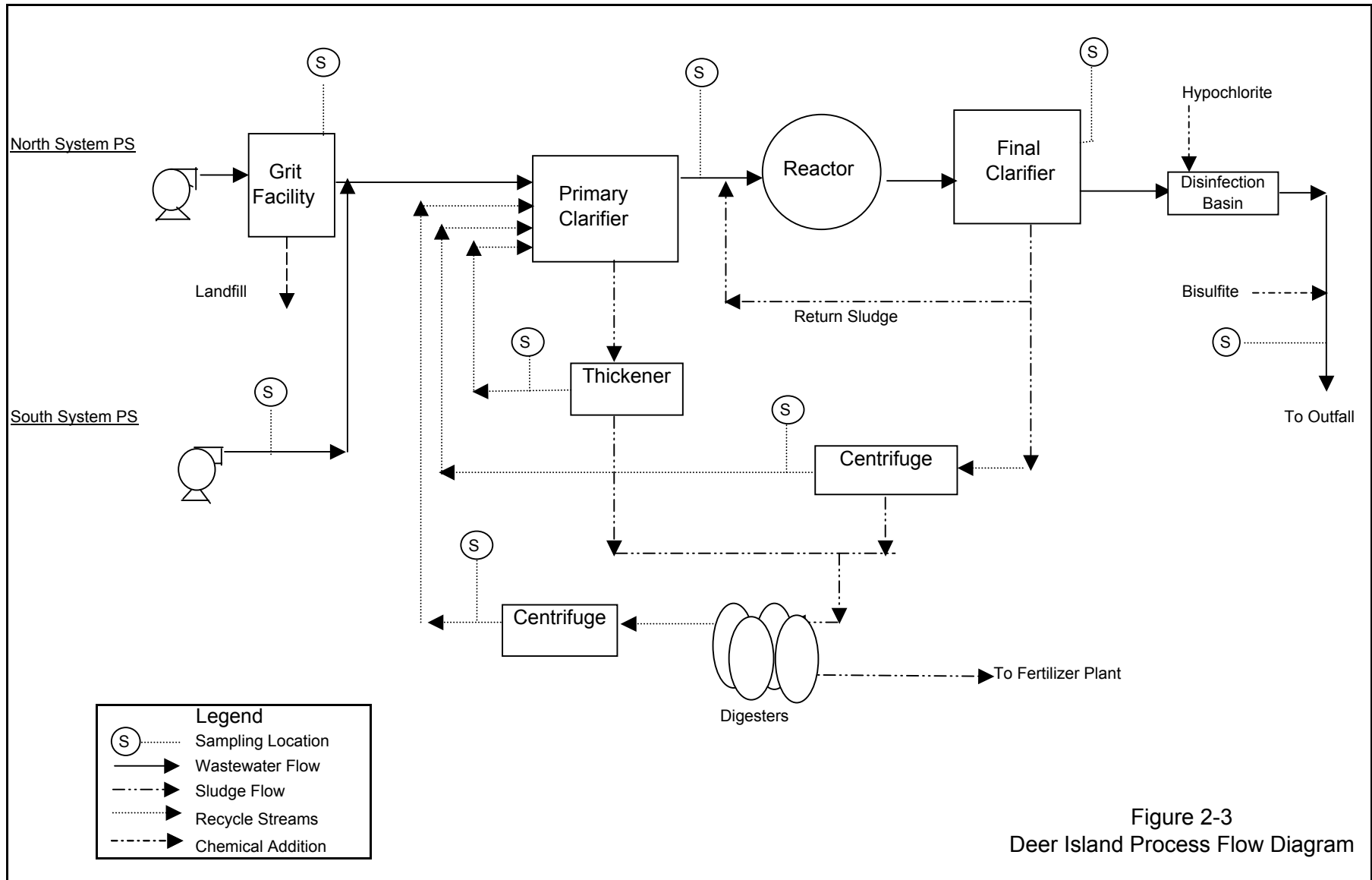
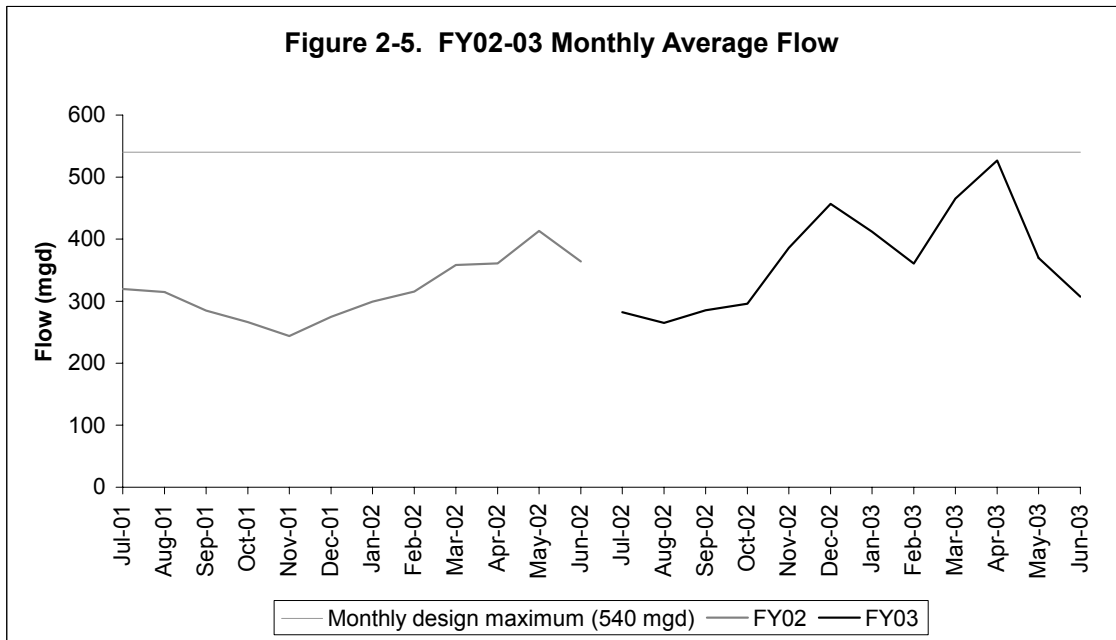
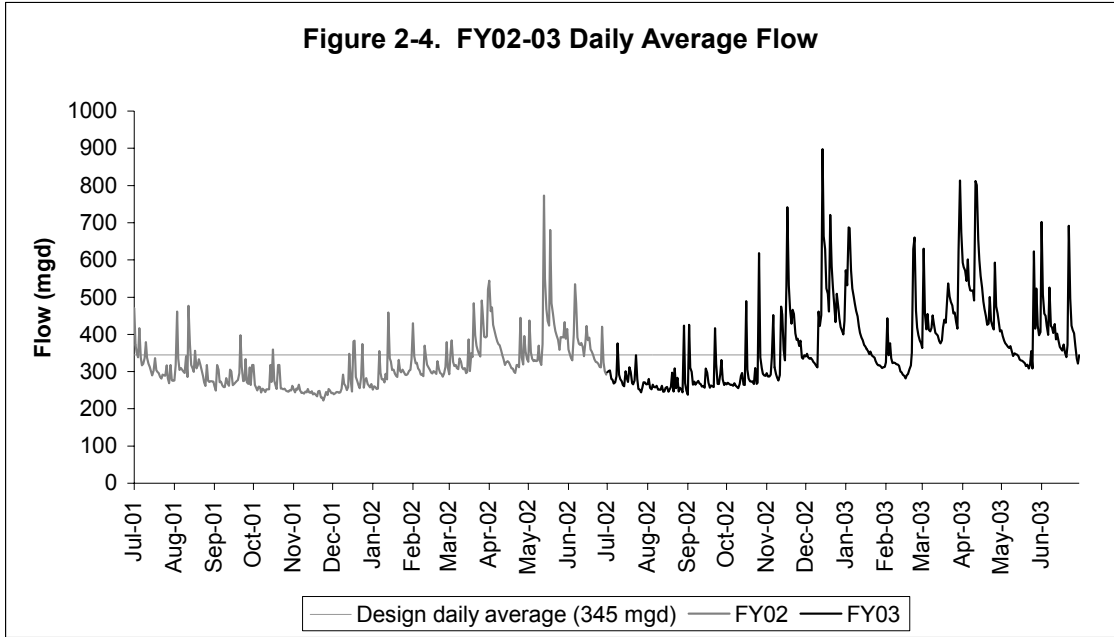

Figure 2-3
Deer Island Process Flow Diagram



2.3.2 Nitrogen Loads

Extensive nitrogen data have been gathered from the nitrogen monitoring program. Whereas past reports used estimated nitrogen loads, actual data are now available to quantify nitrogen in the major waste streams at Deer Island.

Monitored nitrogen species include ammonia-nitrogen (NH_3^-), nitrites (NO_2^-), nitrate (NO_3^-), and total Kjeldahl nitrogen (TKN), all expressed as nitrogen. Total nitrogen (TN) is the sum of TKN, NO_3^- , and NO_2^- . For each monitoring event, the actual flow for each waste stream is used to derive the daily loads of each nitrogen species. The TN load is determined from these calculated loads.

The flow-weighted Deer Island raw wastewater concentration of ammonia is 18.8 mg/L and TN is 32.5 mg/L. These concentrations are typical of a medium-strength wastewater². TN load from raw influent is about 91,700 lbs/d.

During the monitoring period of February 2002 to June 2003, return flows from residual processing contributed about 21% of the total nitrogen load to the primary clarifier. Of the return flows, centrate from the waste sludge centrifuge has the highest load. On an average, the total nitrogen load from these recycled streams is 25,000 lbs/d.

Monitoring data show that the primary clarifiers remove about 19% of the total nitrogen load (raw and recycle streams). An additional 23% is removed by the activated sludge and secondary settling clarifiers. The overall Deer Island TN removal is about 23%, based solely on raw influent and effluent values. Table 2-2 summarizes the average annual concentrations of monitored nitrogen species of the various wastestreams, including the flow-weighted averages of the combined streams. Also presented are the calculated TN loads.

Figure 2-6 shows the monthly average total nitrogen loads to the primary clarifier, while Figure 2-7 shows the total nitrogen effluent loads out of the primary clarifier, secondary clarifier, and final effluent.

² Metcalf & Eddy, Inc. 1991. *Wastewater Engineering: Treatment, Disposal and Reuse*, 3rd ed. p. 109.

**Table 2-2
Summary of FY02 Nitrogen Monitoring Results**

| Sampling Location | Flow* (mgd) | TKN | | NH3-N | | NO3-N | | NO2-N | | NO3/NO2 | | Total Nitrogen | |
|--------------------------------|----------------|--------|--------|--------|--------|---------|--------|---------|--------|---------|--------|----------------|--------|
| | | (mg/L) | (lb/d) | (mg/L) | (lb/d) | (mg/L) | (lb/d) | (mg/L) | (lb/d) | (mg/L) | (lb/d) | (mg/L) | (lb/d) |
| North System Influent | | | | | | | | | | | | | |
| Minimum | 158.6 | 22.0 | 42265 | 10.3 | 22862 | 0.00 | 0 | 0.01 | 14 | ~ | ~ | 22 | 42322 |
| Maximum | 603.8 | 52.3 | 128033 | 34.2 | 61862 | 1.48 | 3865 | 0.72 | 2216 | ~ | ~ | 53 | 130336 |
| Average | 218.8 | 38.5 | 69208 | 22.0 | 38644 | 0.06 | 149 | 0.14 | 291 | ~ | ~ | 39 | 69648 |
| Standard Deviation | 49.8 | 7.2 | 15846 | 5.5 | 7517 | 0.23 | 597 | 0.19 | 516 | ~ | ~ | 7 | 16263 |
| South System Influent | | | | | | | | | | | | | |
| Minimum | 58.7 | 16.8 | 17052 | 8.2 | 10411 | < 0.010 | 0 | < 0.005 | 0 | ~ | ~ | 17 | 17062 |
| Maximum | 201.7 | 48.3 | 47734 | 36.9 | 23818 | 0.07 | 64 | 0.62 | 553 | ~ | ~ | 48.3 | 47734 |
| Average | 97.9 | 29.4 | 23007 | 17.7 | 13528 | 0.00 | 4 | 0.05 | 40 | ~ | ~ | 29.5 | 23052 |
| Standard Deviation | 23.4 | 7.3 | 4448 | 5.9 | 2739 | 0.01 | 11 | 0.12 | 110 | ~ | ~ | 7.2 | 4432 |
| Calculated Raw Influent | | | | | | | | | | ~ | ~ | | |
| Minimum | 222.7 | 21.0 | 59318 | 10.0 | 33273 | < 0.01 | 0 | < 0.01 | 14 | ~ | ~ | 21.1 | 16455 |
| Maximum | 773.0 | 47.7 | 151467 | 31.9 | 74341 | 0.98 | 3865 | 0.55 | 2216 | ~ | ~ | 47.7 | 153770 |
| Average | 316.6 | 35.7 | 91988 | 20.6 | 52245 | 0.04 | 146 | 0.11 | 323 | ~ | ~ | 35.8 | 92457 |
| Standard Deviation | 69.0 | 5.8 | 16114 | 4.6 | 7714 | 0.14 | 541 | 0.15 | 493 | ~ | ~ | 5.7 | 16455 |
| Recycle Streams** | | | | | | | | | | | | | |
| Digested sludge centrate | | | | | | | | | | | | | |
| Minimum | 0.04 | 72 | 2221 | 12.7 | 363 | ~ | ~ | ~ | ~ | 0 | 0.0 | 72 | 2221 |
| Maximum | 1.68 | 260 | 9584 | 34.0 | 1253 | ~ | ~ | ~ | ~ | 0.06 | 2.0 | 260 | 9586 |
| Average | 0.79 | 133 | 4488 | 24.6 | 818 | ~ | ~ | ~ | ~ | 0.02 | 0.6 | 133 | 4489 |
| Standard Deviation | 0.30 | 44 | 1888 | 5.6 | 249 | ~ | ~ | ~ | ~ | 0.02 | 0.6 | 44 | 1888 |
| Waste sludge centrate | | | | | | | | | | | | | |
| Minimum | 1.88 | 1400 | 2244 | 1120 | 1594 | ~ | ~ | ~ | ~ | 0.03 | 0.1 | 1400 | 2245 |
| Maximum | 8.39 | 4570 | 26680 | 1880 | 21248 | ~ | ~ | ~ | ~ | 0.32 | 2.3 | 4570 | 26680 |
| Average | 5.32 | 2122 | 11832 | 1418 | 8302 | ~ | ~ | ~ | ~ | 0.15 | 0.7 | 2122 | 11833 |
| Standard Deviation | 1.51 | 717 | 6919 | 172 | 5078 | ~ | ~ | ~ | ~ | 0.10 | 0.7 | 717 | 6919 |
| Gravity thickener overflow | | | | | | | | | | | | | |
| Minimum | 3.05 | 25 | 1157 | 10.4 | 492 | ~ | ~ | ~ | ~ | 0.00 | 0.0 | 24.72 | 1158 |
| Maximum | 8.07 | 336 | 17105 | 54.8 | 3011 | ~ | ~ | ~ | ~ | 1.38 | 66.2 | 336 | 17105 |
| Average | 5.62 | 119 | 5608 | 26.9 | 1298 | ~ | ~ | ~ | ~ | 0.10 | 4.7 | 119 | 5612 |
| Standard Deviation | 0.69 | 81 | 3842 | 12.1 | 656 | ~ | ~ | ~ | ~ | 0.33 | 15.9 | 80 | 3841 |

**Table 2-2
Summary of FY02 Nitrogen Monitoring Results**

| Sampling Location | Flow* (mgd) | TKN | | NH3-N | | NO3-N | | NO2-N | | NO3/NO2 | | Total Nitrogen | |
|--------------------------------------|----------------|--------|--------|--------|--------|--------|--------|---------|--------|---------|---------|----------------|--------|
| | | (mg/L) | (lb/d) | (mg/L) | (lb/d) | (mg/L) | (lb/d) | (mg/L) | (lb/d) | (mg/L) | (lb/d) | (mg/L) | (lb/d) |
| Calculated Primary Influent** | | | | | | | | | | | | | |
| Minimum | 236.37 | 24.8 | 78855 | 10.6 | 41124 | ~ | ~ | ~ | ~ | 0.01 | 17.4 | 25 | 80309 |
| Maximum | 784.3 | 50.2 | 179773 | 26.5 | 87794 | ~ | ~ | ~ | ~ | 1.03 | 4156.2 | 50 | 182077 |
| Average | 328.3 | 38.8 | 122993 | 19.9 | 62579 | ~ | ~ | ~ | ~ | 0.26 | 912.5 | 39 | 123905 |
| Standard Deviation | 68.5 | 6.5 | 22879 | 4.0 | 11706 | ~ | ~ | ~ | ~ | 0.27 | 1048.9 | 6 | 23224 |
| Primary Effluent | | | | | | | | | | | | | |
| Minimum | 230.0 | 23.0 | 70259 | 11.6 | 44646 | ~ | ~ | ~ | ~ | 0.00 | 0.0 | 23 | 70290 |
| Maximum | 792.9 | 49.5 | 134865 | 35.3 | 77568 | ~ | ~ | ~ | ~ | 0.38 | 1514.7 | 50 | 134865 |
| Average | 322.8 | 36.1 | 93440 | 24.0 | 61567 | ~ | ~ | ~ | ~ | 0.03 | 103.1 | 36 | 93543 |
| Standard Deviation | 71.9 | 6.8 | 12428 | 5.9 | 9092 | ~ | ~ | ~ | ~ | 0.08 | 297.5 | 7 | 12463 |
| Secondary Effluent | | | | | | | | | | | | | |
| Minimum | 226.8 | 16.6 | 52168 | 10.4 | 35154 | ~ | ~ | ~ | ~ | 0.00 | 0.0 | 17 | 52371 |
| Maximum | 432.1 | 36.9 | 89165 | 38.8 | 84605 | ~ | ~ | ~ | ~ | 2.20 | 5658.4 | 38 | 92283 |
| Average | 310.7 | 27.1 | 68866 | 22.2 | 55840 | ~ | ~ | ~ | ~ | 1.05 | 2732.6 | 28 | 71598 |
| Standard Deviation | 47.5 | 5.1 | 9241 | 5.4 | 9424 | ~ | ~ | ~ | ~ | 0.42 | 1219.8 | 5 | 9389 |
| Final Effluent | | | | | | | | | | | | | |
| Minimum | 222.4 | 15.1 | 47639 | 9.4 | 35658 | < 0.01 | 0 | < 0.005 | 0 | 0.02 | 37.0 | 17 | 49900 |
| Maximum | 772.9 | 35.0 | 119366 | 32.0 | 70908 | 2.86 | 10208 | 1.260 | 4540 | 2.68 | 10813.4 | 37 | 125442 |
| Average | 318.0 | 26.0 | 67246 | 21.2 | 53871 | 0.87 | 2385 | 0.349 | 993 | 1.28 | 3523.4 | 27 | 70670 |
| Standard Deviation | 68.4 | 5.3 | 11782 | 5.2 | 7970 | 0.77 | 2276 | 0.269 | 966 | 0.64 | 2086.1 | 5 | 12591 |

- Notes:
- * Flows reported are averages of the whole fiscal year, however, the flow-weighted concentrations were calculated using flows during sampling events. Average loads are calculated using all the data points.
 - ~ No samples collected.
 - ** Recycle streams sampling commenced in February 2002; the calculated primary influent concentrations therefore only include the last five months of the fiscal year (February 2002 to June 2003).

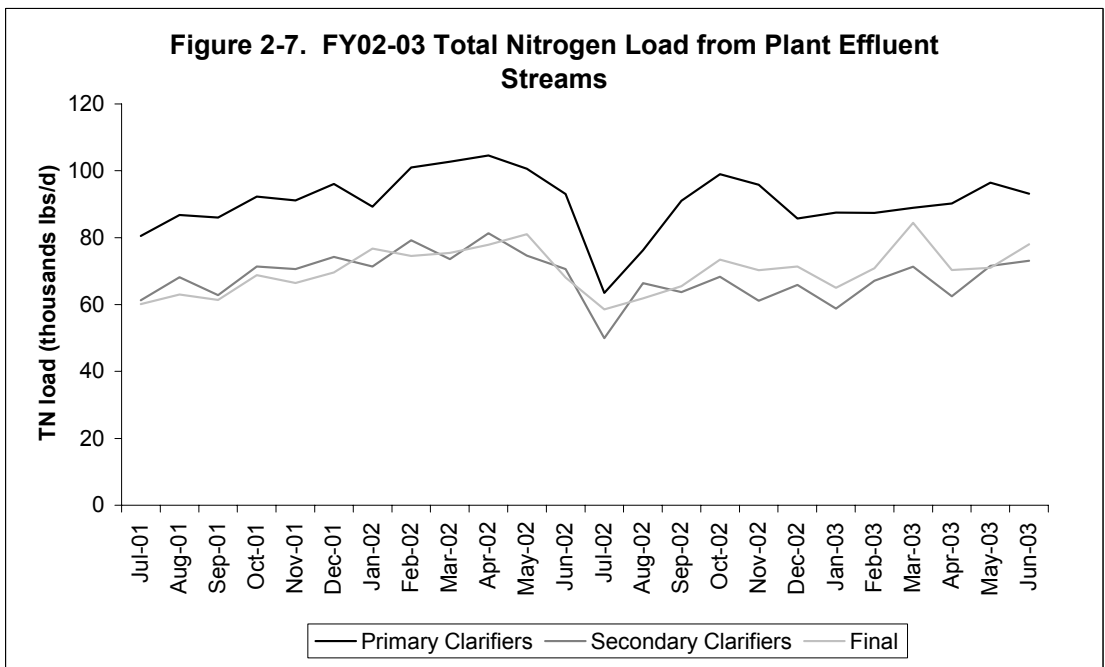
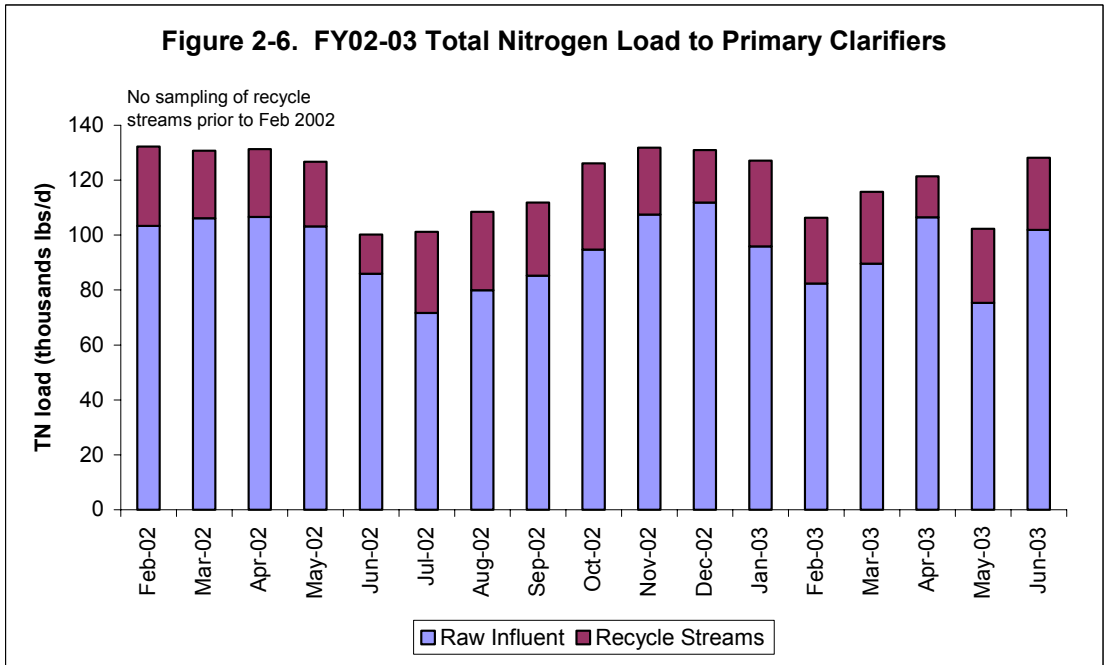

2.4 Basic Design Information

To develop a conceptual design for a nitrogen removal system, some basic information is required. This includes ambient temperature, design flows and loads, and the target effluent quality.

2.4.1 Wastewater Temperature

Wastewater temperature is important for sizing biological systems for nitrification. As in most biochemical reactions, temperature greatly influences nitrification rates. The rate of ammonium oxidation depends on the growth rate of the bacteria *Nitrosomonas*, which in turn depends on temperature. Based on monitoring data and the possible requirement for year-round nitrification, the report uses the consultant's recommendation of a minimum wastewater temperature of 11°C (51.8°F) is used in this report. Ambient wastewater temperature measurements of the south system influent average about 5°F lower than the north system influent.

Final effluent is probably the best source for determining the ambient temperature in designing a biological nitrogen removal system. There were three days during this monitoring period when the temperature dipped below the 51.8°F design criterion. Plant performance would deteriorate during very cold weather but the lessened performance should not cause the plant to fail its NPDES permit.

Figures 2-8 and 2-9 graph the north and south system influent temperatures, respectively, while Figure 2-10 depicts effluent temperatures during the monitoring period.

2.4.2 Design Flows and Nitrogen Loads

Deer Island can provide a maximum-day hydraulic capacity of 780 mgd for secondary treatment. However, to allow for plant operation without polymer addition, the secondary maximum is 540 mgd. The revised estimate of plant flow capacity does not affect sizing of units for biological nitrogen treatment, because their design is based on organic and nitrogen loads, rather than on flow, and loads at Deer Island are largely independent of flow.

The design average plant flow of 345 mgd, which is close to the average influent flow of 347 mgd for the monitoring period in Table 2-3, is used for this analysis. Using the design average daily flow and maximum monthly flow of 345 and 540 mgd respectively, the corresponding average loads of nitrogen in primary and in secondary effluent are presented in Table 2-3. Table 2-3 also compares previous load estimates with more current data. As shown, the estimates used in previous reports compare well with actual data.

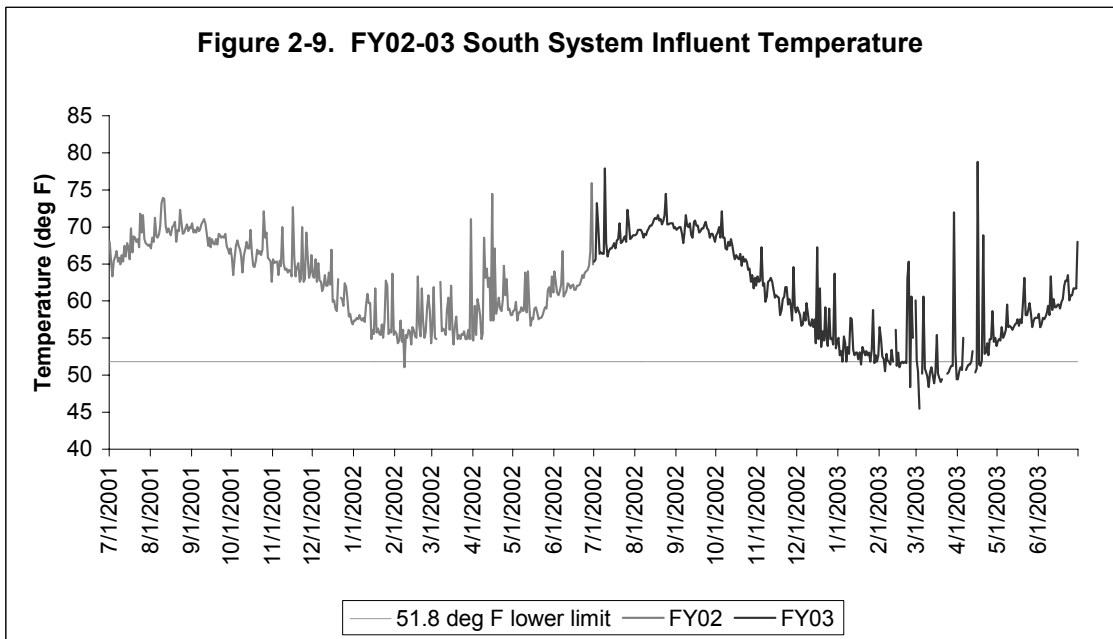
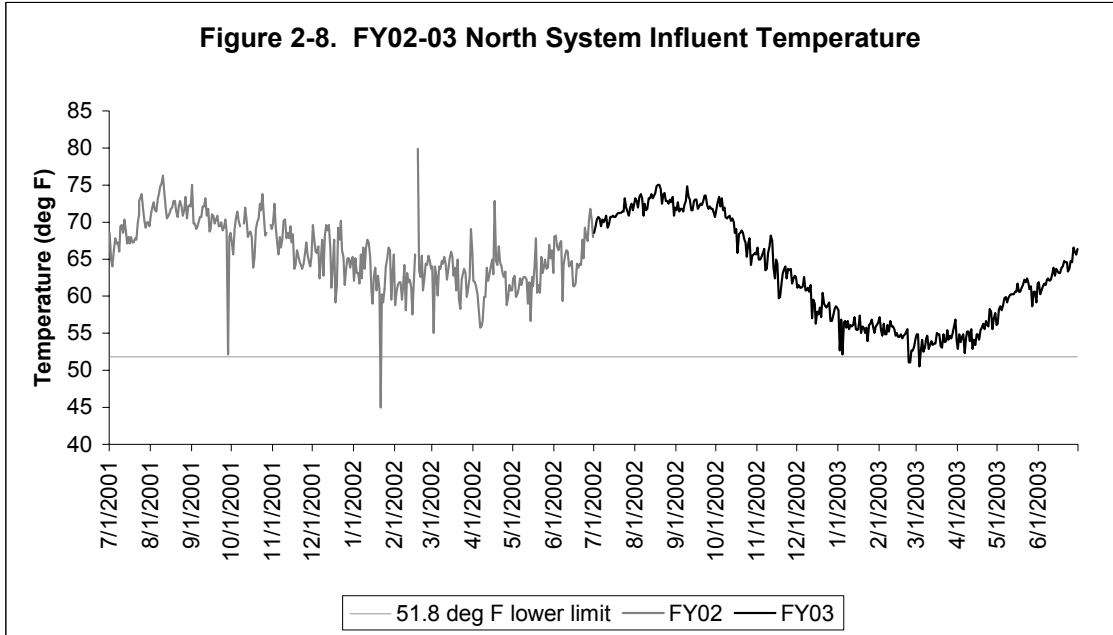

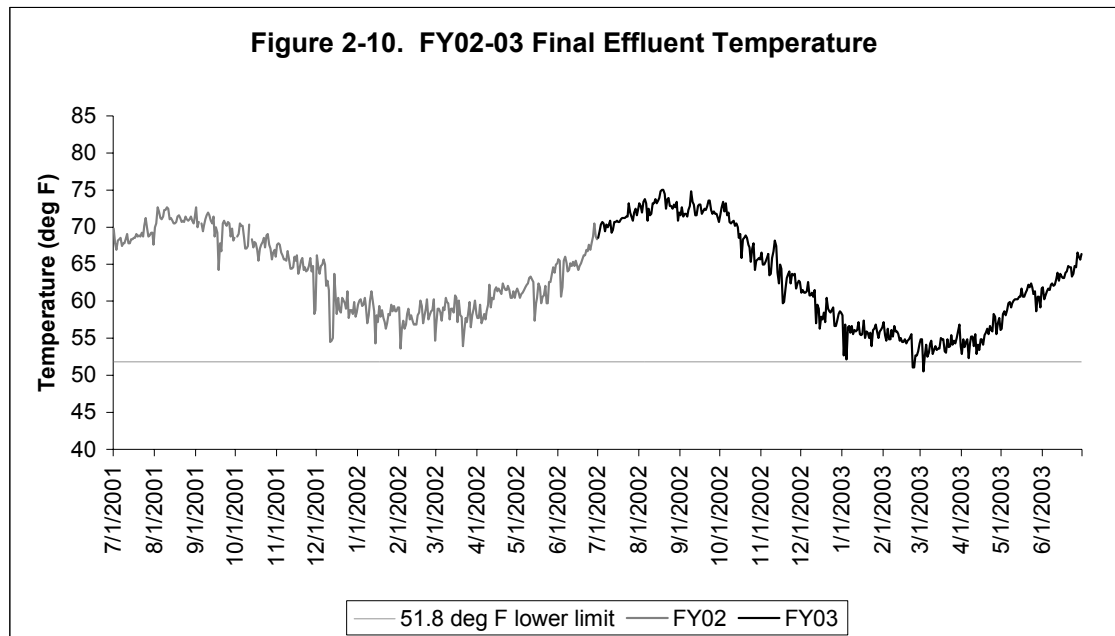

**Table 2-3
Flows and Nitrogen Loads**

| | Flow (mgd) | Primary Effluent Nitrogen Load | | Secondary Effluent Nitrogen Load | |
|---------------|-----------------------|---|-----------------------|---|-----------------------|
| | | 2001* | FY02- FY03 | 2001* | FY02- FY03 |
| Average – Day | 345 | 80,600 | 91,500 | 66,200 | 68,300 |
| Max – Month | 540 | 104,700† | 104,500 | 86,000† | 81,320 |

* Based on limited monitoring data (July-December 1999) and estimated total nitrogen loads from residuals processing recycle flows.

† Estimated.

2.4.3 Required Effluent Quality

Limits for nitrogen in effluent from Deer Island have not been set. This evaluation considers two levels of effluent quality: 4 mg/L and 8 mg/L of total nitrogen, both year-round. These concentrations reflect typical effluent standards for nitrogen. Conceptual land requirements and site layouts are conservatively based on the lower effluent limit because it requires more space for nitrogen removal.

Section 3

Screening of Alternatives

This section identifies processes available to remove nitrogen from wastewater and screens them to generate a list of alternatives appropriate for further evaluation. Table 3-1 summarizes the alternatives, and Section 4 examines them in detail.

Nitrogen removal technologies fall into three basic camps: physical/chemical processes, biological processes, and hybrids of the two.

3.1 Physical/Chemical Processes

Physical/chemical processes rely on basic chemical reactions to remove nitrogen species. Physical/chemical processes employed for nitrogen removal include reverse osmosis, ammonia stripping, ion exchange, and breakpoint chlorination.

Reverse osmosis is expensive and requires a high degree of pretreatment; its use is not necessary to achieve potential nitrogen standards at Deer Island.

Ammonia stripping requires addition of lime to raise the pH of wastewater to about 11. At this pH, ammonia is present as a gas, rather than as the ammonium ion. The limed wastewater is sprayed over a packing material, with air added counter current to the liquid flow to strip the ammonia gas. A problem with this alternative is that power requirements and ammonia emissions are high, and the calcium carbonate scale that forms on the packing requires a high level of maintenance.

In ion exchange, wastewater is passed through a bed of material that exchanges sodium or potassium in the exchange material for the ammonium ion in wastewater. When the ion-exchange material becomes exhausted, passing a caustic solution through the bed regenerates it. Regeneration releases the adsorbed ammonium ions, which are collected in the exhaust solution. Ammonia in the exhaust can be recovered for use as a fertilizer. A problem with ion exchange is high operation and maintenance costs and headloss resulting from suspended solids build-up on the resin.

With breakpoint chlorination, chlorine at high doses oxidizes ammonia nitrogen to nitrogen gas. Dechlorination is needed after breakpoint chlorination, and volatile organic compounds such as chloroform and other trihalomethanes are formed. Breakpoint chlorination must be preceded by treatment beyond secondary treatment, typically coagulation, settling, and filtration, thus making it most effective on polished effluents. A problem with this alternative is that the chlorine demand will be too great to allow for cost-effective implementation.

Physical/chemical processes remove nitrogen only in the ammonia form. They do not remove organic nitrogen or nitrite and nitrate. They have never been used extensively, and their use is declining, so there are few plants now using physical/chemical processes for nitrogen removal. Physical/chemical processes are judged to be inappropriate for use at Deer Island.

3.2 Biological Processes

Biological nitrogen removal involves two processes in sequence: nitrification in an aerobic environment and denitrification in the absence of oxygen. In nitrification, ammonia is oxidized to nitrite and then to nitrate. In denitrification, nitrate is reduced to nitrogen gas. For denitrification to occur at an appreciable rate, suitable concentrations of organic material must be present. In some configurations, the organic matter present in the wastewater is sufficient for denitrification to occur. For other configurations, a supplementary source, such as methanol, must be provided.

Processes available for biological nitrification and denitrification include suspended-growth systems, fixed-film systems, and hybrid systems. In hybrid systems, fixed-film material is added to the aeration tank of suspended-growth systems.

3.2.1 Suspended Growth Systems

Deer Island uses the activated-sludge process to provide secondary treatment. The activated sludge units at Deer Island include aeration tanks and secondary clarifiers. Options for use of the activated sludge process for nitrogen removal at Deer Island include:

- Sequencing batch reactors;
- Membrane activated sludge systems;
- Two-stage activated sludge; and
- Single-stage activated sludge.

Sequencing Batch Reactors

Sequencing batch reactors combine biological activity and settling in a single tank, rather than separating these functions in an aeration tank and a clarifier. They do not save space, however, and control and piping become complicated for large facilities. They are not evaluated further in this report.

Membrane Activated Sludge Systems

Membrane activated sludge systems use membranes to separate effluent from biomass, instead of clarifiers. Their advantage is that the concentration of mixed liquor in aeration tanks can be much higher than with conventional

activated sludge. With higher concentrations, the volume of aeration tanks can be decreased. Membrane activated sludge systems have not been used at plants larger than about one mgd, however. Membrane activated sludge systems are not further evaluated in this report.

Two-Stage Activated Sludge

When activated sludge systems were first used for nitrification, they were designed and built as two-stage systems, with the first stage designed to remove biochemical oxygen demand and the second stage designed to oxidize ammonia. It is now recognized that single-stage nitrification is feasible, and, except for special cases, today's treatment plants feature single-stage nitrification.

At Deer Island, two-stage nitrification would require construction of aeration tanks and clarifiers after the existing units. There is not enough space remaining to build these units, and two-stage nitrification is thus impractical.

Single-Stage Activated Sludge

Nitrification and denitrification can be obtained in a single-sludge system, such as the Modified Ludzack-Ettinger (MLE) process and step feed variation of the activated-sludge process. The MLE process modifies an aeration tank of an activated sludge system by incorporating an anoxic zone ahead of an aeration section designed to provide nitrification. Mixed liquor, which contains nitrate, is returned to the anoxic zone, and nitrate is reduced to nitrogen gas. The step-feed process can achieve denitrification by providing alternating anoxic and aerobic zones. This process has been used successfully in New York City.

To provide nitrification in cold weather (when the wastewater temperature can be 11°C or colder), the solids retention time (SRT) would have to be increased to about 11 days. Current design provides for an SRT of less than 3 days. So, more aeration tanks would be needed. An aeration volume equal to about seven of the existing three aeration batteries would be required. The area required (about ten acres) exceeds the space available with reasonable geometry and this option is dropped from further evaluation. Addition of an anoxic zone would require even more area. No additional clarifiers would need to be constructed, however, because flows would not increase.

3.2.2 Fixed Growth Systems

In fixed-film systems, the biological organisms grow on a supporting surface, in contrast to suspended-growth systems, where the organisms grow in a liquid phase and then have to be separated from effluent in clarifiers. Fixed film systems include rotating biological contactors, nitrifying trickling filters,

biological aerated filters and submerged packed-bed reactors, fluidized bed reactors, and moving bed biofilm reactors.

Rotating Biological Contactors

Rotating biological contactors (RBCs) consist of disks rotating on shafts arranged so that all or part of the disks are submerged. Excessive growth sloughs from the disks and is captured in clarifiers. For aerobic treatment, the disks are submerged to about 40% of their diameter. For denitrification, the disks are completely submerged. Mechanical reliability of RBCs can be a problem and RBCs are not often used at large treatment plants. Therefore, RBCs will not be reviewed further in this report.

Trickling Filters

Trickling filters can be used for nitrification after BOD removal, sometimes without the need for settling tanks. A preliminary comparison of the area required for trickling filters and of space available at Deer Island showed that space is insufficient. Additional odor control may be required for trickling filters. Nitrifying trickling filters will not be reviewed further.

Submerged Packed-Bed Reactors

Submerged packed-bed reactors are similar in configuration to biological aerated filters. They are not provided with aeration, however, and methanol is usually added to the feed stream to provide a carbon source. Like biological aerated filters, submerged packed-bed reactors require backwashing to remove trapped solids and excess biological growth. In the 1997 report, submerged packed-bed reactors were considered separately from deep-bed filters. Because of their common features, these two systems are treated as one in this report. As in the 1997 report, submerged packed beds are further evaluated.

Nitrification and denitrification can be achieved in a single packed-bed that combines the features of a biological aerated filter and of a submerged packed-bed reactor. In this type of reactor, the packed-bed is about three meters deep. The diffusers are set at about two meters beneath the surface, so that the lower section is not aerated and denitrification takes place in the lower section. Methanol is required with secondary effluent because secondary effluent does not contain enough carbon for denitrification to proceed sufficiently. This combined nitrification/denitrification process has not been attempted at large plants and is not retained for further evaluation.

Fluidized-Bed Reactors

Fluidized-bed reactors are tanks filled with 4 to 10 feet of sand or other medium to support the growth of biomass. Wastewater is fed from the bottom of the reactor at a velocity high enough to fluidize the bed. (This contrasts

with biological aerated filters, where the bed is not fluidized during normal operation.) Excessive growth shears from the medium and is separated from treated effluent in an upper zone of the reactor. These units were evaluated in the 1997 report for nitrification and for denitrification. The system supplier now believes that other options are preferred for nitrification, and fluidized-bed reactors are not retained for further study for nitrification. Fluidized-bed reactors are retained, however, for denitrification.

Moving-Bed Biofilm Reactors

The moving-bed biofilm reactor (MBBR) process consists of a tank filled with small plastic elements. The hollow cylindrical elements are about 1 cm in all dimensions and have ridges on the exterior and a crosspiece on the inside. A clarifier is required to separate excess growth. With air addition, MBBR can be used for nitrification. With methanol addition, the process can be used for denitrification. This process is recommended for further evaluation.

Biological Aerated Filters

Biological aerated filters (BAFs) consist of fully submerged, stationary beds of medium about 3 or 4 mm in diameter. Flow through the system is usually upward (although there are some downflow systems), and air diffusers are placed at the bottom of the filter. Periodically, the filters are backwashed to remove accumulated solids. The backwash water requires treatment and is usually returned to the main wastewater flow after settling. BAFs were evaluated in the 1997 report, and are retained here for further evaluation.

3.2.3 Hybrid Systems

Hybrid systems are sometimes called integrated fixed-film activated sludge systems. The fixed-film material placed in the suspended-growth tanks includes ropes, sponges, trickling filter media, RBCs and the media used for MBBR. These materials could be placed in the existing aeration tanks and increase their capacity. Capacity is increased because biomass grows on the fixed-film material as well as in the suspended phase. The 1997 report noted that more experience would be needed before the option could be recommended. Since then, additional information has become available, but rates for nitrification still need further research (Sen *et al* 2000).¹ This report does not further evaluate hybrid systems, but they should be considered if MWRA decides to conduct pilot tests of alternative nitrification systems. Pilot testing could be used to determine appropriate design criteria.

¹Sen, D., *et al.* 2000. *Investigation of Hybrid Systems for Enhanced Nutrient Control*. Project 96-CTS-4, Water Environment Research Foundation.

**Table 3-1
Alternatives for Controlling Nitrogen at the Deer Island Treatment
Plant**

| | Total Nitrogen Removal |
|------------------------------------|-----------------------------------|
| Physical/Chemical Processes | |
| Ammonia Stripping | X |
| Ion Exchange | X |
| Breakpoint Chlorination | X |
| Reverse Osmosis | X |

| | Nitrification | Denitrification |
|-------------------------------|----------------------|------------------------|
| Biological Processes | | |
| Suspended Growth | | |
| Sequencing Batch Reactors | X | X |
| Membrane Activated Sludge | X | X |
| Single Stage and Two Stage | X | X |
| Fixed Film | | |
| Rotating Biological Contactor | X | X |
| Nitrifying Trickling Filter | X | |
| Biological Aerated Filters | X | |
| Fluidized-Bed Reactors | | X |
| Submerged Packed-Bed Reactor | | X |
| Moving-Bed Biological Reactor | X | X |
| Hybrid Systems | | |
| Rope Media | X | X |
| Sponge Media | X | X |
| Trickling-Filter Media | X | X |
| Rotating Biological Contactor | X | X |
| MBBR Media | X | X |

3.3 Systems Retained for Further Evaluation

Table 3-2 shows systems retained for further evaluation. These systems were chosen based on ability to handle the flows and nitrogen loads at Deer Island, as well as experience with cost, reliability, and ability to fit into the available land at the treatment plant.

Table 3-2
Systems for Further Evaluation

| | <i>Nitrification</i> | <i>Denitrification</i> |
|-------------------------------|-----------------------------|-------------------------------|
| Biological Aerated Filters | X | |
| Submerged Packed Bed Reactors | | X |
| Fluidized-Bed Reactors | | X |
| Moving Bed Biofilm Reactor | X | X |

Section 4

Evaluation of Alternatives

This section investigates the alternatives proposed in Section 3 for further evaluation. They are grouped into these process alternatives:

- Biological aerated filters for nitrification with
Submerged packed-bed reactors for denitrification
- Biological aerated filters for nitrification with
Fluidized-bed reactors for denitrification
- Moving-bed biofilm reactors for nitrification and denitrification

Development of the alternatives includes selection of criteria for sizing units and preliminary sizing of components. Alternatives are developed to meet standards of 4 mg/L and 8 mg/L of effluent nitrogen, but are designed conservatively to meet effluent levels of 3 mg/L and 6 mg/L, respectively.

Based on information provided, MWRA's consultant was able to obtain information about proprietary equipment and processes from system suppliers. Recommendations from the suppliers were reviewed, and professional judgment and experience were applied to select design criteria. The units provided allow for standby, such as for backwashing or other maintenance and for repair.

Oxygen requirements, chemical requirements, and sludge production for each alternative would be about equal. Those needs are covered in Section 4.4.

4.1 Biological Aerated Filters and Submerged Packed-Bed Reactors

Design criteria for nitrification in biological aerated filters (BAFs) and denitrification in submerged packed-bed reactors (SPBRs) are shown on Table 4-1. Two major suppliers provided recommendations for the criteria: Infilco Degremont, Inc., and Kruger, Inc. On the table, the number of units needed to meet nitrogen loads is calculated, based on loading criteria and on unit dimensions.

The table shows that 96 BAFs and 28 SPBRs would be required. These include standby units. To fit on the space available, the units would have to be constructed on two levels. Each level would include half of the units, plus blowers and other ancillary facilities.

To reach the new facilities, secondary effluent, which now flows to an effluent channel south of the secondary clarifiers, would be diverted to a new effluent channel north of the clarifiers and to a new pumping station to lift flow to the new facilities. Effluent from the new facilities would enter a new tunnel discharging to the chlorine contact tanks.

Blowers would provide aeration. The air would be injected at the base of each biological aerated filter and flow upward, co-current with the wastewater flow.

The BAFs and SPBRs both need to be backwashed approximately every two days, using final effluent for backwashing. Backwash waste would be returned to the head of the secondary system or to the head of the plant. Backwash rate is about 25 gpm/ft², for about eight minutes. Air required for backwashing is approximately 5000 scfm/cell.

The gross area required for siting the BAF and SPBR system, including blowers, a pump station and galleries would be about 5.7 acres, the entire available space in the area of secondary Battery D. Figure 4-1 shows the proposed BAF and SPBR layout.

4.2 Biological Aerated Filters and Fluidized-Bed Reactors

The BAF design for this treatment combination would be identical to that described in Section 4.1. Table 4-2 summarizes sizing information for the fluidized bed reactors (FBRs) for denitrification. The FBR design is based on information provided by US Filter. The effluent from the fluidized beds would flow to the chlorine disinfection basin and then be discharged from the facility.

The area requirements for the BAF/FBR system would be approximately 7 acres. This area exceeds the space available in Battery D, but the proposed layout can be incorporated as shown in Figure 4-2.

4.3 Moving-Bed Biofilm Reactors

For this option, Kaldnes provided the design concept criteria. Media would be added to the existing aeration tanks, where nitrification would occur.

Table 4-3 summarizes design criteria for the MBBR nitrification system and Table 4-4 summarizes the MBBR denitrification system. Because the MBBRs would be treating primary effluent, the analysis for MBBRs accounted for nitrogen removed via assimilation into the biomass produced during BOD removal. In the proposed MBBR systems, polyethylene media would be added to the existing aeration tanks. The biomass for biological treatment would grow on the media, thus eliminating the need for recycling solids from the secondary clarifiers. Stainless steel sieves would be installed at the outlets of the aeration basins to retain the media.

Table 4-1
Biological Aerated Filter for Nitrification and
Submerged Packed-Bed Reactors for Denitrification

| | <i>BAF</i> <i>Nitrification</i> | <i>SPBR</i> <i>Denitrification</i> |
|--|--|---|
| TKN Load (lb/d) | | |
| Maximum Month | 81,320 | 81,320 |
| Nitrogen Loading Rate Allowed (lb/d/1,000ft ³) | 40 | 190 |
| Hydraulic Loading Rate Allowed (gpm/ft ²) | 4 | 15 |
| Unit Dimensions | | |
| Depth (ft) | 12.1 | 9.5 |
| Surface Area (ft ²) | 1,940 | 1,940 |
| Volume (ft ³) | 23,474 | 18,430 |
| Active Units | 88 | 24 |
| Units Provided | 96 | 28 |

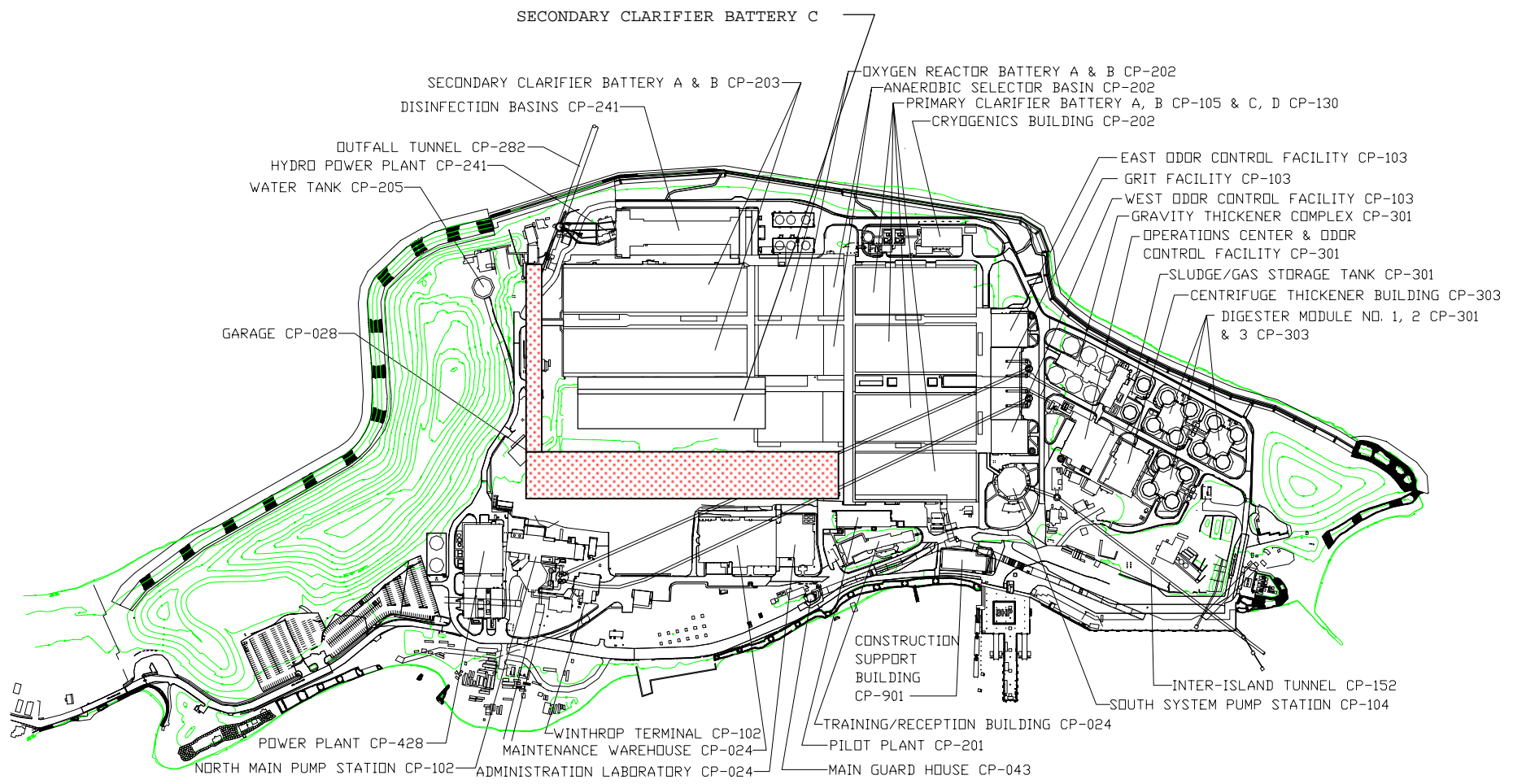
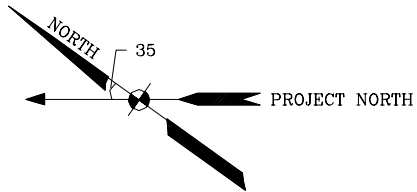

Figure 4-1
Proposed Layout for BAF/SPBR Option

Table 4-2
Biological Aerated Filter for Nitrification and
Fluidized Bed Reactors for Denitrification

| | <i>BAF</i> <i>Nitrification</i> | <i>FBR</i> <i>Denitrification</i> |
|--|--|--|
| TKN Load (lb/d) | | |
| Maximum Month | 81,320 | 81,320 |
| Nitrogen Loading Rate Allowed (lb/d/1,000ft ³) | 40 | 250 |
| Hydraulic Loading Rate Allowed (gpm/ft ²) | 4 | 18 |
| Unit Dimensions | | |
| Depth (ft) | 12.1 | 10 |
| Surface Area (ft ²) | 1,940 | 800 |
| Volume (ft ³) | 23,474 | 8,000 |
| Active Units | 88 | 41 |
| Units Provided | 96 | 48 |

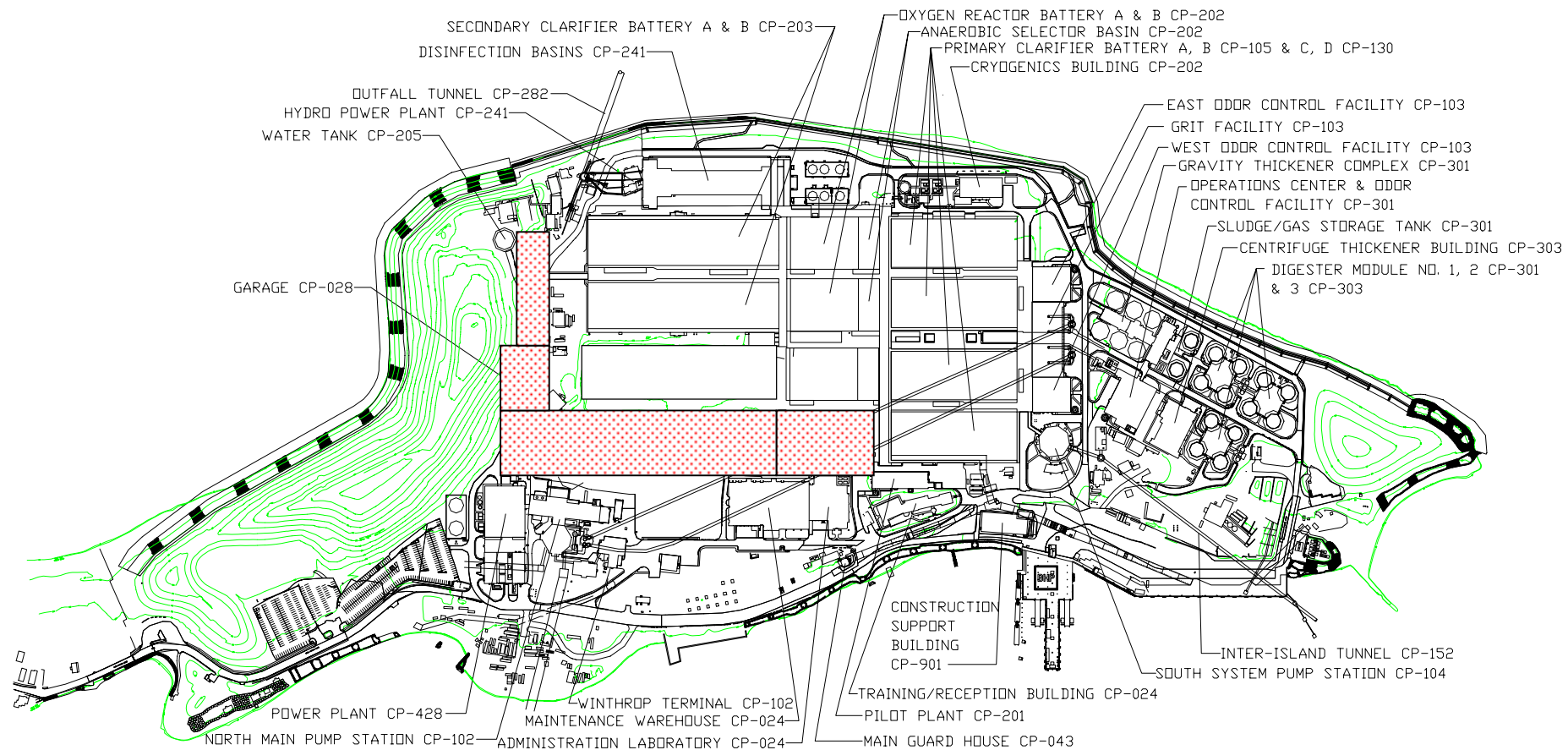
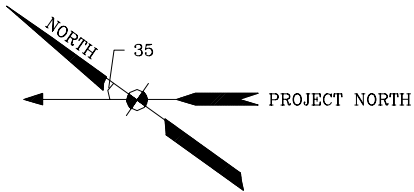

Figure 4-2
Proposed Layout for BAF/FBR Option

The existing on-site pure oxygen aeration system would provide oxygen and mixing. Because the aeration basins would now provide nitrification as well as oxidation of BOD, additional tankage, as described in Table 4-3, would be required to handle the design flows. Additional facilities for producing oxygen would also be required.

Effluent from the aeration basins would be deaerated before flowing to additional MBBRs for denitrification. Deaeration can be accomplished by nitrogen stripping, which drives dissolved oxygen from the wastewater. Nitrogen gas is a by-product of the cryogenic pure-oxygen generation system. This excess nitrogen can possibly be used as the nitrogen stripping source.

New effluent channels would be required to divert flow from the aeration basins to the denitrification MBBRs and then to the existing secondary settling basins for clarification.

For aeration, approximately 4,699,000 ft³ of new tanks would be required. The existing aeration basins provide 4,321,800 ft³. However, with the need to construct two new channels, 485,100 ft³ of aeration volume would be lost from the existing basins. The total new volume required (862,300 ft³) could be located in the space previously allotted for aeration Battery D.

Denitrification would require between 2,100,000 to 2,500,000 ft³ of new construction depending on the level of effluent nitrogen concentration to be met. Prior to denitrification, 152,000 ft³ of deaeration tankage is required to remove dissolved oxygen from the wastewater. Deaeration/denitrification facilities can also be sited in the space previously allocated for secondary clarifier Battery D. Methanol facilities for denitrification would be located between the vehicle maintenance building and the dry storage warehouse.

The proposed MBBR nitrification/denitrification system would require about 6.3 acres. Figure 4-3 shows the conceptual layout of the MBBR nitrification/denitrification system.

Table 4-3
Moving Bed Biofilm Reactor for Nitrification

| | MBBR for Nitrification |
|---|-------------------------------|
| Nitrogen Load in Primary Effluent (lb/d) | |
| Maximum Month | 104,500 |
| Nitrogen Assimilated Plus Ammonia Nitrogen in Effluent (lb/d) | 17,000 |
| Nitrogen Nitrified (lb/d) | 88,000 |
| Nitrification Rate (g/m ² ·d) | 0.931 |
| Specific Surface Area (m ² /m ³) | 500 |
| Total Media Required (ft ³) | 3,029,000 |
| % Fill of Carrier Elements | 65% |
| Total Volume Required (ft ³) | 4,660,000 |
| Total Existing Aerobic Tank Volume (ft ³) | 4,321,800 |
| Volume Lost to New Channel (ft ³) | 485,100 |
| New Volume Provided (ft ³) | 823,300 |
| Unit Dimensions of New Basins | |
| Depth (ft) | 24.5 |
| Surface Area (ft ²) | 4,900 |
| Number of Basins | 12 |

Table 4-4
Moving Bed Biofilm Reactor for Denitrification

| | <i>MBBR for Denitrification</i> | |
|---|---------------------------------|------------------------------|
| | <i>4 mg/L Total Nitrogen</i> | <i>8 mg/L Total Nitrogen</i> |
| Total Nitrate Nitrogen Reduced (lb/d) | 75,000 | 61,000 |
| Loading Rate (g/m ² -d) | 2.45 | 2.45 |
| Specific Surface Area (m ² /m ³) | 500 | 500 |
| Media Required (ft ³) | 981,000 | 798,000 |
| % Fill of Carrier Elements | 40% | 40% |
| Total Tank Volume (ft ³) | 2,500,000 | 2,000,000 |
| Deaeration Volume | 152,000 | 152,000 |
| Tank Dimensions | | |
| Surface Area (ft ²) | 5,929 | 5,929 |
| Depth (ft) | 24.5 | 24.5 |
| Number of Reactors | 18 | 16 |

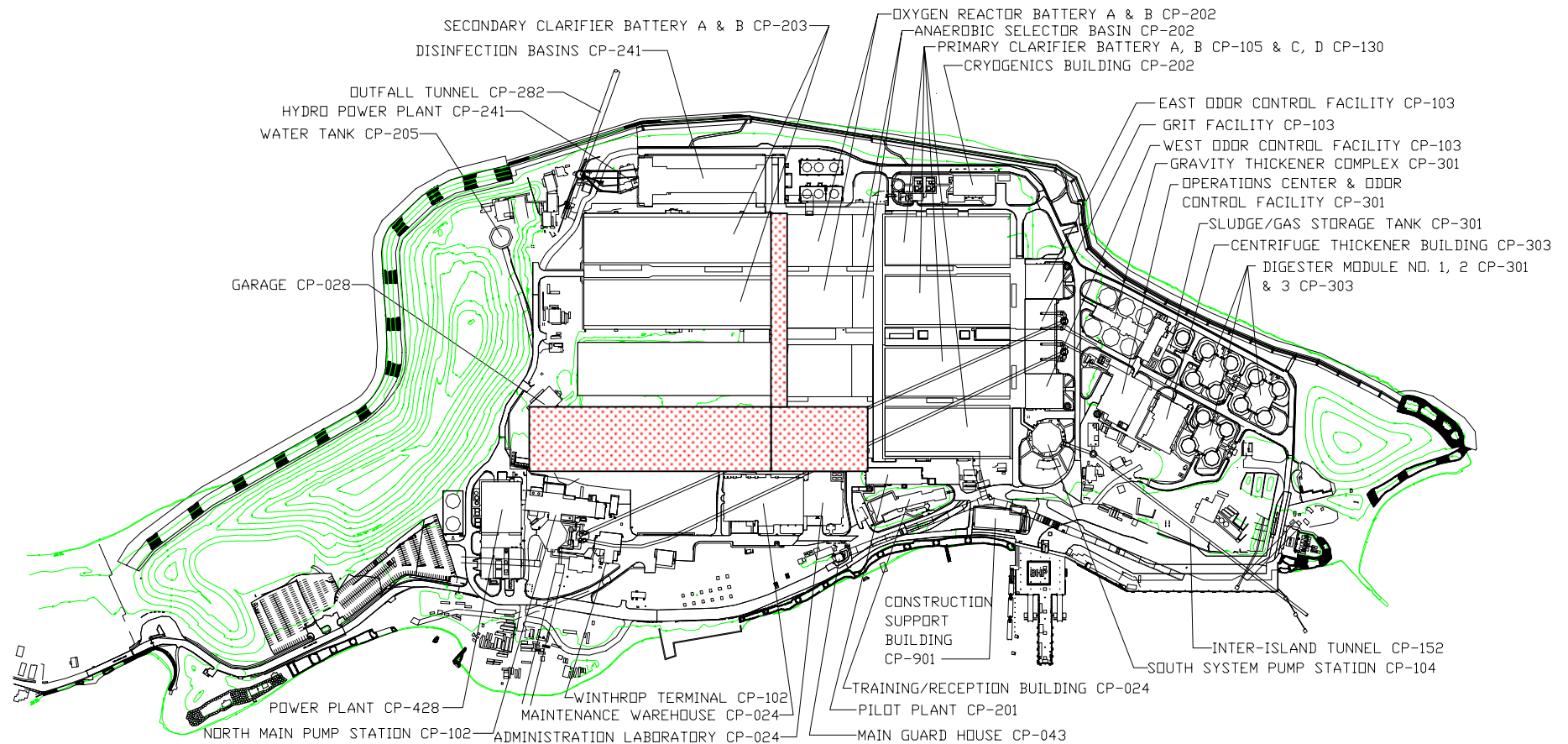
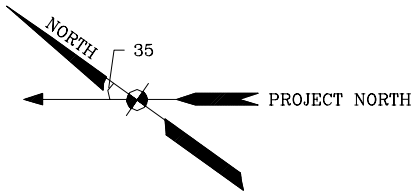

Figure 4-3
Proposed Layout for Nitrification/Denitrification MBBR Option

4.4 Common Elements

Elements common to the three alternatives include oxygen required for nitrification, chemical required for denitrification and additional capacity for processing sludge produced from both nitrification and denitrification systems.

4.4.1 Oxygen Requirement

Nitrification will increase the requirement for oxygen. This section examines two alternatives for providing oxygen.

The first case is for the BAF system, which would process secondary effluent from the existing activated-sludge system and for which air from the atmosphere would be used to provide oxygen. In that case, blowers provided by the system supplier would provide diffused air. The blowers would be housed in the BAF building. During the maximum day, about 280 tons/day of oxygen would be needed. Air use would be about 150,000 cfm at the maximum rate, and connected power for the blowers would be about 7,500 horsepower.

The second case is for the MBBR system, which would process primary effluent. With the MBBR system, high-purity oxygen would be used. Two new 150-ton units would have to be added, to supplement the two 150-ton/day units existing at Deer Island's cryogenic plant.

4.4.2 Chemical Requirements

Denitrification would require addition of methanol. The methanol requirement assumed for all of the denitrification systems is 3 lb methanol per lb of nitrate-nitrogen reduced. Methanol consumption for denitrification would average about 184,000 lb/d for less than 8 mg/L effluent TN concentration and 229,000 lb/d for an effluent TN concentration of less than 4 mg/L at maximum month flows. Two 243,000 gallon methanol storage tanks would be required. Each tank would provide about 14 days of storage.

4.4.3 Sludge Processing

Methanol addition would increase sludge production at the rate of about 0.6 lb/lb of nitrate nitrogen reduced. About 75,000 lb/d of nitrogen would be reduced to achieve 4 mg/L of total nitrogen during the maximum month, and about 45,000 lb/d of additional sludge would thus be produced.

The additional sludge produced would impact thickening of biological sludge and sludge digestion. At a concentration of about 0.6%, additional sludge to be thickened would amount to about 640 gpm. The existing centrifuges have capacity to process the added flow.

The design concentration of thickened biological sludge is 5% and the digesters are sized to provide 15 days of storage at the maximum month. Under these conditions, about 2 million gallons of digestion capacity would be needed. Based on current operating practices, the digesters have enough capacity to handle the additional sludge flow.

4.5 Recommendations for Future Considerations

Biological nitrogen removal technologies appear to be the most cost-effective method of nitrogen removal at this time. In the spring of 2003, the Water Environment Research Foundation research project *Sustainable Technology for Achieving Very Low Nitrogen and Phosphorus Effluent Levels*¹ commenced. This 2-year project will assess a variety of technologies to develop information about the feasibility and cost benefits of nutrient reduction. MWRA will monitor the progress of this study for consideration at Deer Island. Additional considerations in the selection of alternative options include separate treatment of residual processing return flows at Fore River, decreasing methanol requirements, and utilizing the existing pilot plant to study nitrification rates.

4.5.1 Separate Treatment at Fore River

Digested sludge is now thickened at Deer Island, barged to Fore River, and dewatered and dried at Fore River. In the future, digested sludge will be pumped to Fore River, rather than being barged. When that is done, digested sludge will not be thickened at Deer Island.

With all processing of digested sludge taking place at Fore River, all sidestreams from thickening and dewatering digested sludge will be produced at Fore River, with none produced at Deer Island. Sidestreams from processing digested sludge contain high concentrations of ammonia, and it might be economical to treat the sidestreams for nitrogen removal at Fore River. Treatment at Fore River would decrease the size of facilities needed at Deer Island.

4.5.2 Decreasing Requirement for Methanol

All the alternatives considered in Section 4 would require addition of methanol as a carbon source for denitrification. With these options, purchase of methanol would be a major expense. Applying treatment processes that use wastewater to provide the carbon source would decrease use of methanol.

Section 3.2.1 described the Modified Ludzack-Ettinger (MLE) process, which is a modification of the activated sludge process. In that section, it was stated that the MLE process and other modifications of the activated sludge process

¹ *Progress*, Water Environment Research Foundation, Spring 2003 Newsletter, Vol. 14(2).

require more space than is available at Deer Island. The volume (and hence, space) required can be decreased by adding carrier material to the system, to serve as medium on which dense biological growth could be supported. The carrier material could be used to support a fixed film (as discussed in Section 3.2.2) or could be a hybrid system (as discussed in Section 3.2.3). Additional work would be required to assess the kinetics of these systems and to determine how to configure tanks and piping at Deer Island.

4.5.3 Testing at Pilot Plant

The pilot plant at Deer Island was used successfully during the DP-29 study to examine the operation of activated sludge systems. Thought will be given to using the pilot plant to determine kinetics of alternative processes for nitrification and denitrification. The facilities could be used, for example, to determine design requirements for systems that would decrease requirements for methanol (see Section 4.5.2 for description). With a pilot-plant study conducted, design of facilities for nitrogen removal could be more efficient.



Massachusetts Water Resources Authority
Charlestown Navy Yard
100 First Avenue
Boston, MA 02129
(617) 242-6000
<http://www.mwra.state.ma.us>